

# WACKER NEUSON DV90 + DV60 Dual View Dumper

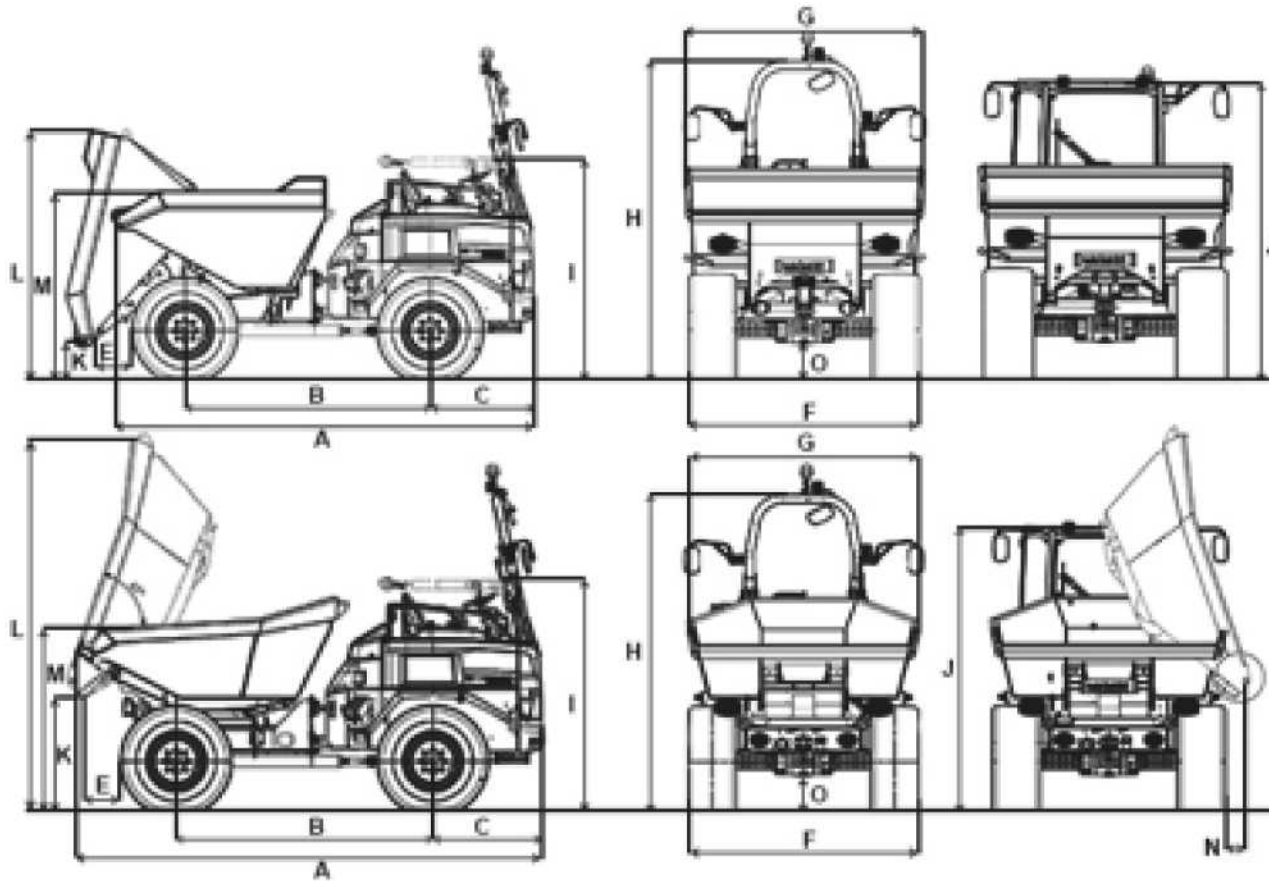

DUMPERS	DV60- 6t(mm)	DV90-9t (mm)	
A	Overall Length: Inc. ROPS cab	4699	4891
B	Wheel Base	2485	2700
C	Rear Overhang	1157	1157
E	Dumping Distance	456	457
F	Width	2230	2420
G	Skip Width	2218	2453
H	Height ROPS	3377	3382
I	Height ROPS Tilted	2300	2405
J	Height Cabin	2940	2945
K	Dump Height Max	1100	1220
L	Skip Height Tilted	3639	3980
M	Skip Height not tilted	1981	2230
N	Dumping distance to side	69	152
O	Ground Clearance	370	358
	Dump Angle °	48°	40.1

Operating Data	DV60	DV90
Payload (Kg)	6,000	9,000
Shipping Weight (Kg)	4,009	4,925
Operating Weight (Kg)	4,355-4,680	5,071-5,396
Skip Capacity (Struck) l	2,350	3,300
Skip Capacity ( Heaped) l	3,150	4,350
Skip Capacity – Water Litres	1,600	2,005L
Articulation angle °	29	29
Turning Radius mm	5,980	6,491
ENGINE DATA-	Duetz TD2.9L L4	Duetz TD2.9L L4
Type	Watercooled 4 cyl. Turbo Diesel	Watercooled 4 cyl. Turbo Diesel
KW	55.4	55.4
Displacement l	2.9	2.9
Emissions – EU regulation	V	V
TRANSMISSION	4 Wheel Drive Hydrostatic	4 Wheel Drive Hydrostatic
Max Travel Speed- (Km/h)	30	30
Gradeability %	55	50
Tyres	405/70-20	500/60-22.5
Fuel Tank Capacity (L)	80	80
Sound Level ( LWA) dB(A)	101	101

**To discuss your production or rental requirements  
in more detail call our rental team on 0161 761 5109**

All data gathered from the manufacturer & accurate at time of publication. This data sheet is provided as a guide only. Please check against manufacturer data on all critical requirements.

## Simply see more.

The Dual View dumper clearly stands above the requirements of the line-of-sight standard ISO 5006:2017.

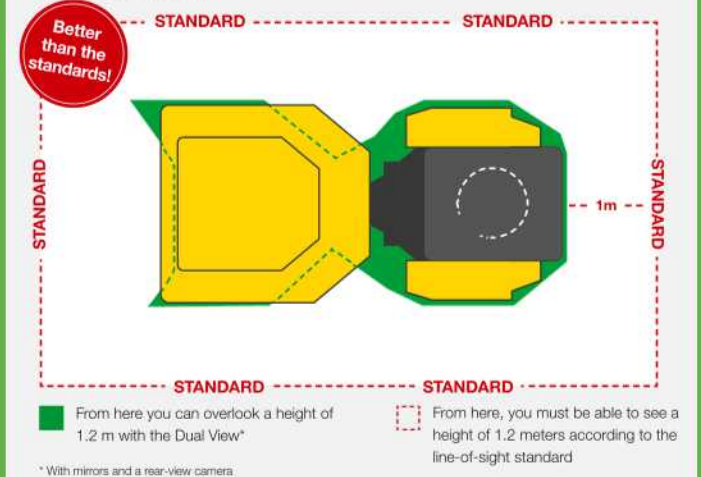

## Large Comfort Cab.



## More operating comfort thanks to the ergonomic swivel console.



## Swivel tip skip

Thanks to the infinitely variable 180-degree tipping, the swivel tip skip puts your material exactly where you want it – ideal.

- Levelling when transporting liquids on gradients.
- 2 x 90-degree turn motor left and right.
- Side filling possible





## WACKER NEUSON DV90 + DV60 Dual View Dumper

### SAFETY & SECURITY

All the equipment is installed with the following additional equipment to enhance safe and secure use.

1. High Resolution Colour reverse camera
2. Reverse audible movement alarm
3. Green Light seat belt warning
4. Anti- Theft Satellite tracking
5. On board Diagnostic Data logging
6. Hi Visibility Access steps